

Thank you for purchasing SANWA SGS-02.  
This operation manual is to explain how to use SGS-02 for safety uses.  
Please read carefully and keep the operation manual after reading.

### Caution and Warnings

- The SGS-02 is designed specifically for use with SANWA transmitter.
- The products is not waterproof. Please do not use in raining as excessive moisture.
- After driving RC car, please keep it to take off the battery.

### SGS-02 Feature

SGS-02 is for the automatically motion control for opposite lock (counter-steering).  
It use any categories as F1 and Drift and adjust setting values for various categories.

#### Main Features

- High quality competition grade gyro system
- New system "QUICK" function can make ideal motion
- Compatible with SXR (SANWA Extreme Response) mode (will be the best smooth motion)
- The setting can be set by SANWA transmitter (AUX-ADJ, CODE10)
- Aluminum case is installed and compact gyro

### HOW to Set / Initial Setting

Please set the below contents before install the SGS-02 to car.

1. Car steering is same way with transmitter steering. (If steering is opposite way please set by REV on the transmitter)
2. Please set neutral steering setting. (If neutral is not correct, please set by SUB TRIM on the transmitter)
3. Please set End Point Adjustment for both right and left steering. (If not setting, please set by EPA on transmitter)

\*In case of not setting in the above contents, please set the contents by transmitter.  
Please check transmitter manual when setting the above contents.

In case of improper setting, gyro cannot be worked correctly and might be caused servo broken.

#### 1. SGS-02 Connection

Please connect servo to the ③ and connect ② to receiver CH1

\* Please do not use ① at initial setting.

- ① AUX / SSL input connector
- ② Steering Data input connector
- ③ Steering Data output connector

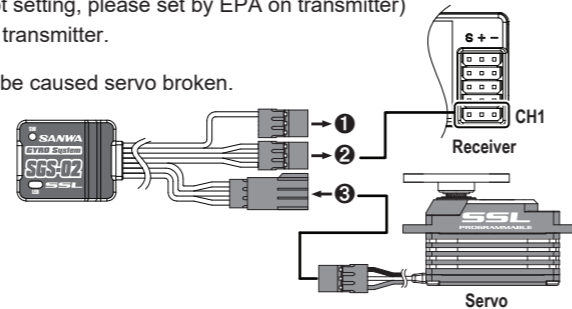

#### 2. How to Install SGS-02

Please install the SGS-02 as right figure by double side tape.

\*SGS-02 cannot correctly work with wrong installation.

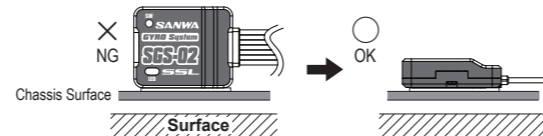

#### 3. Initial Setting (Limit Mode)

1. Turn on the transmitter
2. Press with holding SGS-02 SW and turn on car power. (LED Status: Red Lighting / Blue and Green is flashing)
3. Turn right on transmitter steering until end. Then, press SW. (LED Status: Green flashing change to Green lightning after press SW)
4. Turn left on transmitter steering until end. Then, press SW. (LED Status: Blue flashing change to Blue lightning after press SW)
5. Finish default setting (LED Status: Green, Red, and Blue lightning. After 2 seconds, the lights will be blinking. Then, Blue lightning.)

\*In case of setting REVERSE, green and blue light will work opposite.



#### 4. Gyro Operation Direction Checking

Please move car as the right figure.

In case steering will work opposite side, the initial setting is finished.

Please turn off the car.

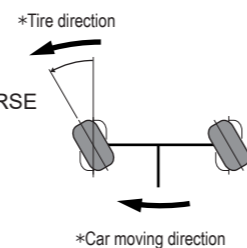

\* In case steering will NOT work opposite side, it need to change SGS-02 REVERSE setting by PROGRAM MODE or MULTI SETTING GEAR.  
Please check how to change the setting in PROGRAM MODE contents.

\* Steering will work opposite side by moving car

### Caution Before Driving

- Caution before tuning on the car  
Please turn on the transmitter first. With the car sitting on a stable flat surface, and turn on the receiver.  
Please do not turn right or left steering on the transmitter when turning on the receiver.  
\*It will cause on inappropriate neutral position.
- In case of using SANWA PGS servo series, hunting will be happened by PGS setting.  
Please check PGS setting recommendation in last page of the manual.

### HOW to SET GYRO SETTING CONTENTS

To change each setting values is in the below methods.

- Change SGS-02 Setting Methods
    1. Changing setting values by PROGRAM MODE
    2. Changing setting values by MULTI-SETTING GEAR
  - Change SGS-02 Setting Methods by the SANWA transmitter (Wireless setting from transmitter)
    3. Changing setting values by AUX
    4. Changing setting values by CODE10
2. and 4. methods are needed to prepare devices.  
2. method needs MULTI-SETTING GEAR.  
4. method needs receivers and transmitter are compatible with CODE10 (CODE5 is not compatible).

\*In case of using MULTI-SETTING GEAR, please update firmware for SGS-02.

Please check SANWA HP for firmware (Firmware ver is same as PGS-HR).

\*Please also check devices are compatible with CODE10 and SSL function on SANWA HP.

### GYRO FUNCTION

SGS-02 can be set each function values in the below.

#### ● GAIN

Function is for setting gain.

In case of increasing gain setting, the car will be stable.

#### ● QUICK

Function is for quick car movement.

In case car will be difficult to turn due to high gain, car will be easy to turn by increasing QUICK values.

#### ● SPD-FW/SPD-RT (Speed-Forward/Return)

Function is for reduce gyro movement speed.

F(Gyro movement speed when initial cornering), R(Gyro movement when servo will be back to the neutral position)  
In case of reducing gyro movement speed, the car will be smooth and the car movement will be as real car.

#### ● GY-LIM (Gyro Limiter)

Function for limited the gyro movement.

Mainly, the function will be used for F1. In case gyro worked too much, the gyro movement will be limited by increasing value.

#### ● AVE-FL (Average Filter)

Function is for reducing servo hunting.

In case of nonprogrammable servos, hunting might be happened.  
Hunting will be less by increasing the value.

#### ● REVERSE

Function is for gyro movement reverse.

In case of gyro movement is opposite in default setting, it will be set reverse.

#### ● SXR-OUT

Function can be gyro out put will be SXR (SANWA Extreme Response) mode.  
Even if device is incompatible with SXR mode, gyro out put will be SXR mode.  
(\*The function is required to use servo is compatible with SXR mode.)

#### ● AUX-ADJ (AUX Adjust)

Function is setting content change by AUX.

SGS-02 can change AUX setting content by AUX-ADJ function.

AUX-ADJ function can choose one content from GAIN, QUICK, SPD-FW/SPD-RT, GY-LIM, and AVE-FL.

#### ● GAIN-LV (Gain Level)

Function is for changing gain rate.

In case of changing gain rate, SGS-02 will fit to any categories as F1 and Drift.  
Basically, F1 set 0.5 and Drift set 1.

## Example of the Connection for SGS-02

- SGS-02 is different to set up by using device function.  
In case of setting GAIN, QUICK, SPD-FW, SPD-RT, GY-LIM, and AVE-FIL, Please refer in the below.  
\*Please also check devices are compatible with CODE10 and SSL function on SANWA HP.

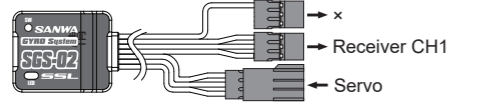
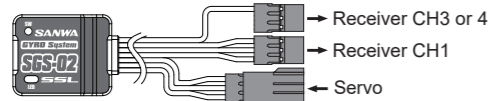
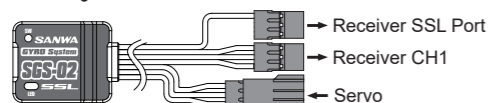
Connection	How to Set	Example devices
<ul style="list-style-type: none"> <li>In case of not connecting AUX or device is not compatible with AUX</li> </ul> 	①PROGRAM MODE ②MULTI-SETTING GEAR	2CH Transmitter
<ul style="list-style-type: none"> <li>In case device is compatible with AUX</li> </ul> 	①PROGRAM MODE ②MULTI-SETTING GEAR ③AUX	Transmitter is incompatible with CODE10 Receiver do not have SSL port *In case of using FH5 RF mode
<ul style="list-style-type: none"> <li>In case of using SSL/CODE10</li> </ul> 	④CODE 10	Transmitter is compatible with CODE10 Receiver is compatible with SSL

### ① Setting by PROGRAM MODE

- In case of setting by program mode
- 1. Please connect gyro as the below picture. LED light will be turned on blue after turning on the transmitter and car.

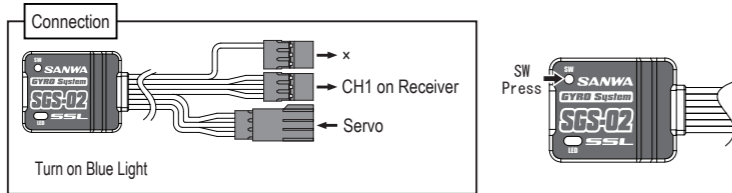

2. Press SW with holding for 2 second. LED will be flashing green and blue light and will be in program mode.
3. In the program mode, press SW to move setting contents: ①→②→③
4. Please press SW with holding for 2 seconds on the setting contents. Mode will be in setup mode and can set select setting content.
5. In setup mode, red and green light will be flashing. Press SW to set values: #1→#2→#3.
6. Press SW with holding for 2 seconds and setting value will be changed.
7. When finished setting value, mode will be returned on program mode.
8. Press SW to change setting content after ⑩, the program mode will be finished and save setting value to SGS-02.

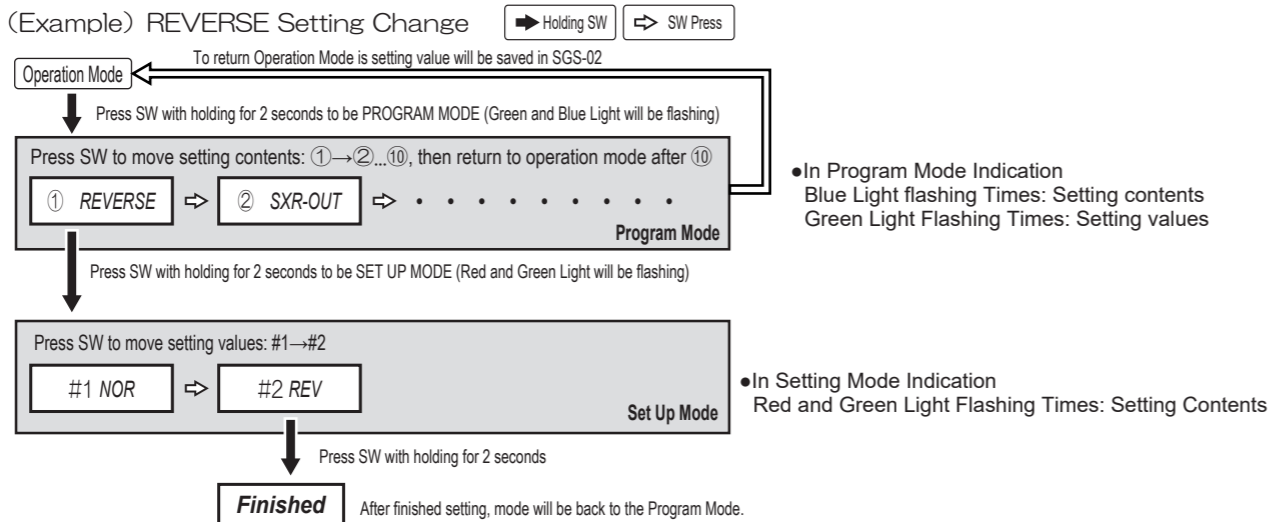

Program Mode Contents List (Default: )

Blue Light Flashing Times	Setting Contents	#: Green Light Flashing Times										
		#1	#2	#3	#4	#5	#6	#7	#8	#9	#10	#11
①	REVERSE	NOR	REV									
②	SXR-OUT	OFF	ON									
③	AUX-ADJ	GAIN	QUICK	SPD-FW	SPD-RT	GY-LIM	AVE-FL					
④	GAIN-LV	×0.5	×1.0									
⑤	GAIN	0%	10%	20%	30%	40%	50%	60%	70%	80%	90%	100%
⑥	QUICK											
⑦	SPD-FW											
⑧	SPD-RT	0%	10%	20%	30%	40%	50%	60%	70%	80%	90%	100%
⑨	GY-LIM											
⑩	AVE-FL											

- \*In case of connecting AUX/SSL input connector to receiver SSL port, Program Mode can be set only ①~④
- \*In case of not connecting SXR compatible servo, please DO NOT turn on SXR-OUT function.
- \*In case of turning on the SXR-OUT function, please restart the car. The setting will not apply until restart.

### ② Setting by MULTI-SETTING GEAR

- In case of setting by MULTI-SETTING GEAR(Optional), setting will be available to connect setting data input connector to MULTI-SETTING GEAR.  
\*Please also check how to use MULTI-SETTING GEAR on SANWA HP.  
Setting values can be set 0~100 by MULTI-SETTING GEAR.

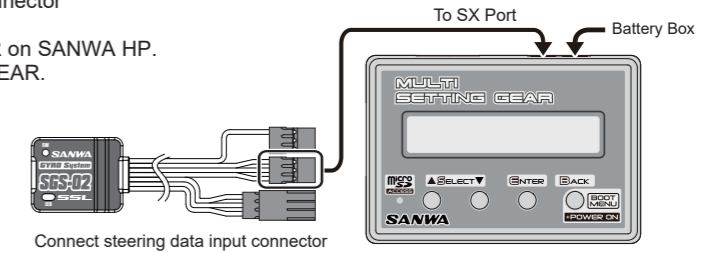

### ③ Setting by AUX Function

- In case of setting by AUX function(\*required more than 3ch transmitter and receiver), setting will be available by transmitter.  
Connect AUX/SSL port to receiver CH3 or CH4.  
When turning on the car, SGS-02 light will be turned on blue and red.  
Default setting is GAIN setting.

Connecting to receiver CH3 can be set by AUX1. Connecting to receiver CH4 can be set by AUX2.  
AUX setting depends on transmitters. Please check transmitter's manual.

- To change AUX-ADJ setting by PROGRAM MODE or MULTI-SETTING GEAR, AUX can change to set for QUICK, SPD-FW, SPD-RT, GY-LIM, or AVE-FL.  
\*AUX response mode is only available with NOR or SHR.

### ④ Setting by CODE10

- In case of setting by CODE10(\*required transmitter and receiver are compatible with CODE10), setting will be available by transmitter CODE10 function.  
Setting data by CODE10 can be saved in SGS-02.  
1. Connect SGS-02 AUX/SSL input connector to receiver SSL port.  
2. Transmitter AUX2 set CODE10.  
3. Check SGS-02 Light is turned on green and blue.  
4. Set each setting value by AUX2 CODE 1 - 6.

- How to save setting by CODE10  
Setting data by CODE10 can be saved in SGS-02.  
After setting value by CODE10, enter in program mode. Then finished program mode will be saved CODE10 setting in the SGS-02.  
In case of using saved data, please take off SSL/AUX connector from receiver SSL port, then restart car.  
Please check green light will be off when restarted.

- \*CODE5 is not compatible with SGS-02
- \*SXR response mode is not available to use CODE10.
- \*SSL-CH set "5" as default setting. Basically, the SSL-CH is not needed to change. Please keep SSL-CH setting is "5".

## List for Setting Contents

●Setting availability is different to use Program Mode, MULTI-SETTING GEAR, AUX, and CODE10.

①Setting by Program Mode

□ In case of connecting to SSL port, D01 - 06 apply to CODE1 - 6.

②Setting by Multi-Setting Gear

③Setting by AUX function

■ Available to set contents by AUX-ADJ

④Setting by CODE10

\*1 GAIN/QUICK/SPD-FW/SPD-RT/GY-LIM/AVE-FL

Setting Contents	Setting Range	①	②	③	④
SSL-CH	5 - 8	×	○	×	×
M01 REVERSE	NOR/REV	○	○	×	×
M02 SXR-OUT	ON/OFF	○	○	×	×
M03 AUX-ADJ	※1	○	○	×	×
M04 GAIN-LV	×0.5 / 1.0	○	○	×	×
D01 GAIN	0 - 100%	○	○		○CODE1
D02 QUICK		○	○		○CODE2
D03 SPD-FW		○	○	■	○CODE3
D04 SPD-RT		○	○		○CODE4
D05 GY-LIM		○	○		○CODE5
D06 AVE-FL		○	○		○CODE6

## List for LED Light Indication

●Please check light for current SGS-02 condition.



○→On  
△→Flashing  
☆→Blinking  
—→Off

\*Setting REVERSE on transmitter will be switched green and blue light in LIMIT MODE.

MODE	LED			CONDITION
	Blue	Red	Green	
	☆	☆	☆	No signal from transmitter
(Default) Limit Mode	△	○	△	Start Limit Mode
	△	○	○	Complete a side steering setting
	○	○	○	Complete an another side steering setting
	☆	☆	☆	Finish Limit Mode Setting
Operation Mode	○	-	-	Operate by internal setting
	○	○	-	Operate by internal setting + AUX
	○	-	○	Operate by CODE10
Program Mode	△	-	△	Program Mode
	-	△	△	Set Up Mode
	○	○	○	Finish Set Up Mode

## Trouble Shooting

●Servo does not work.

In case of flashing blue and green light, SGS-02 works in PROGRAM MODE and servo will not work. Please finish Program Mode or restart car.

In case of using servo is incompatible with SXR responses mode and turn on SXR-OUT setting, Servo does not work. Please turn off SXR-OUT function by Program Mode or MULTI-SETTING GEAR.

●Servo cannot point neutral position.

In case of setting gyro limit and QUICK setting value is above 1, neutral disposition might be happened. Please set QUICK value is "0" when setting gyro limit.

●Gyro does not work.

SGS-02 GYRO-GAIN might set "0". Please check GYRO-GAIN setting by Program Mode or MULTI-SETTING GEAR. Also, please check CODE1 setting is not "0" in case of using CODE10 by transmitter.

●Servo hunting

In case Boost and Stretcher values in Programmable servo (PGS servos) set high values, hunting will be happened. Please use the servo to decrease Boost and Stretcher values.

In another case is gyro works by car vibration.

SGS-02 is structured to avoid effect by car vibration. If the SGS-02 worked by the vibration, please use thick double side tape or place the SGS-02 apart from car motor.

## Service and Support



SANWA ELECTRONIC INSTRUMENT CO.,LTD.

1-2-50, YOSHIDA HONMACHI  
HIGASHI OSAKA, 578-0982 JAPAN  
PHONE :81-72-962-1277  
FACSIMILE :81-72-964-2831



## Flow Chart for Gyro Setting

●Please refer SGS-02 Setting in the below.

Contents	For Drift	For F1
<b>GAIN</b>	In case car is not stable during the corner	
	Car will be stable to increase GAIN value. *Servo might be hunting to increase GAIN value. Please set not to be hunting.	
<b>QUICK</b>	In case car does not turn well during the corner by increased GAIN value	
	Car does not turn well to increase GAIN value. Please increase QUICK value to turn well without decreasing GAIN value.	
<b>GY-LIM</b>	In case of feeling counter is strong	In case of feeling not turn during tight corner
	Gyro maximum movement is limited by increased GY-LIM value. Counter maximum will be limited to adjust cornering during the drifting.	Gyro maximum movement is limited to increase GY-LIM value. Car turn well during tight corner even if cannot turn by only gyro operation.
<b>AVE-FL</b>	In case of servo hunting (as vibration)	
	Hunting will be decreased to increase the value. AVE-FL averaged gyro function, gyro works will be slowly.	Basically do not use the function for F1
<b>SPD (FW/RT)</b>	In case of feeling gyro is too fast In case of being real car movement	
	Gyro movement will be slowly to increase FW and RT setting values. Basically, set closed values for both FW and RT.	Basically do not use the function for F1

Setting Steps



## PGS Servo Recommendation for Drift

●Please refer in the below PGS servo setting for drift.

Contents	PGS-LH/LH2	PGS-CL/CL2
STRECT	5 - 10	10 - 20
BRAKE	50 (Default)	30 - 40
MV-FRQ	100	100
MV-HLD	0	0

\*Please start to try default setting except the above setting.